

# MS2510

Mariner Kit for use with HP EliteDesk 800 G4 Tower PC (Desktop configuration)



The HP EliteDesk 800 G4 Tower (TWR) PC is marine type approved by all of the major international marine Classification Societies when it is installed in conjunction with our Mariner Kit MS2510.

The MS2510 Mariner Kit is designed to fit onto any horizontal surface and affords protection against the effects of vibration and shock experienced in the offshore marine environment and has been tested against IACS Unified Requirement E10 and the relevant sections of IEC60945 (see below right for test details).

This type approved combination of hardware and Mariner Kit can be used as the platform for your critical navigation, control, loading and general purpose applications (please check individual type approval certificates for any restrictions).

**“Steer the right course with Mariner Systems”**



## PRODUCT FEATURES

- ◆ Raise the bar for performance, security, and manageability
- ◆ Powered for the enterprise, the HP EliteDesk 800 G4 TWR is one of HP's most secure and manageable PCs featuring superb expandability in a stylish chassis designed for the modern workplace
- ◆ Intel® Q370 chipset supporting Intel® 8th Generation Core™ processors featuring integrated Intel® UHD Graphics and Intel® vPro™ Technology (available with Core i5 and Core i7 processors)
- ◆ Five bays and four full-height slots including one slot for full-length double-wide graphics, plus three additional M.2 slots, and plenty of configurable ports.
- ◆ Two front (including one fast charging) and two rear USB 2.0 ports; two rear USB 3.1 Gen 1 ports; two front and two rear USB 3.1 Gen 2 ports; one front USB Type-C 3.1 Gen 2 port
- ◆ 2 x DisplayPort™ 1.2; 1 x RJ45 Network connector; 1 x RS-232 Serial port (optional)
- ◆ ENERGY STAR® certified and EPEAT® Gold registered where applicable/supported
- ◆ CCC, CECP and SEPA certified
- ◆ Compliant with the Restrictions of Hazardous Substances (RoHS) directive – 2011/65/EC
- ◆ Compliant with REACH regulations – 1907/2006
- ◆ Designed to comply with the Waste Electrical and Electronic Equipment (WEEE) directive – 2012/19/EU
- ◆ PC chassis and all internal components and modules are manufactured with low halogen content
- ◆ Three-year limited warranty on parts and labour as standard

This Mariner system is tested against the consolidated 'worst-case' requirements of the following major international marine Classification Societies:

**ABS, BV, CCS, ClassNK, DNV GL, KR, LR, PRS, RINA**

Tests included on the test programme are as follows:

- > Vibration, Shock, Static and Dynamic Inclination
- > Dry & Damp Heat, Low Temperature
- > Acoustic Noise, Compass Safe Distance
- > High Voltage, Power Supply Variation & Power Supply Failure
- > Conducted LF & RF, Electromagnetic Field
- > Radiated & Conducted Emissions, Electrostatic Discharge
- > Insulation Resistance, Burst / Fast Transients
- > Surge Immunity, Access to Dangerous Voltages

# MS2510

## Mariner Kit for use with HP EliteDesk 800 G4 Tower PC (Desktop configuration)

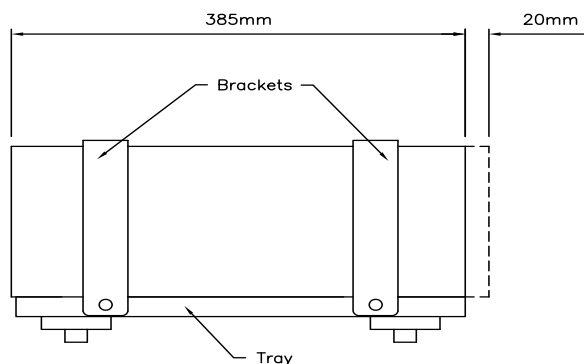
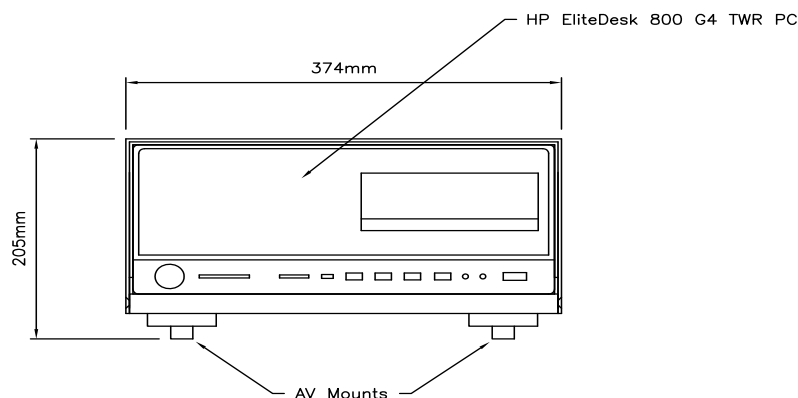

**Mariner Systems (UK) Limited**  
 Oaklands Park • Wokingham • Berkshire • RG41 2FD • United Kingdom  
 Telephone: +44 (0) 118 979 6020 • Facsimile: +44 (0) 118 979 6021  
 sales@marinersystems.com • www.marinersystems.com

## OPERATING GUIDELINES

Although all our equipment is tested against extreme environmental conditions for the purposes of marine type approval, installation should take into account the following guidelines:

- > Keep the computer away from excessive moisture, direct moisture and the extremes of heat and cold and, wherever possible, ensure that the unit is operated within the manufacturer's specified operating ranges:

	Operating	Non-Operating
<b>Temperature</b>	+10° to +35°C (+50° to +95°F)	-30° to +60°C (-22° to +140°F)
<b>Humidity</b>	10% to 90% (non-condensing)	5% to 95% (non-condensing)

- > Leave at least 10.2 cm (4-inch) clearance on all vented sides of the computer to permit the required airflow
- > Never restrict airflow into the computer by blocking any vents or air intakes
- > Occasionally clean the air vents on all vented sides of the computer
- > If the computer is to be operated within a separate enclosure, intake and exhaust ventilation must be provided on the enclosure, and the same operating guidelines listed above will still apply

By following these guidelines you will maximise the life of your computer and minimise service costs.

## STATISTICS

<b>Overall Fitted Dimensions</b>	374mm (w) x 205mm (h) x 405mm (d)
<b>Weight (Mariner Kit only)</b>	2.4 kg
<b>Weight (including hardware)</b>	Starting at 12.3 kg (depends upon configuration)
<b>Chipset</b>	Intel® Q370
<b>Available Processors</b>	Intel® 8th Generation Core™ i7, i5 & i3; Intel® 8th Generation Pentium®;
<b>Memory</b>	Up to 64 GB DDR4-2666 DIMM
<b>Hard Drive(s)</b>	500 GB to 2 TB 3.5-inch SATA (7,200 rpm); 500 GB to 1 TB 2.5-inch SATA (7,200 rpm); 500 GB 2.5-inch SATA SED Opal 2 (7,200 rpm); 256 GB 2.5-inch SATA SED Opal 2 TLC SSD; 256 GB 2.5-inch SATA SSD; 128 GB M.2 2280 PCIe TLC SSD; 1 TB PCIe-3x4 NVMe TLC SSD; 256 GB to 512 GB M.2 2280 PCIe NVMe SSD; 256 GB to 512 GB M.2 2280 PCIe NVMe TLC SSD
<b>Keyboard</b>	HP USB Business Slim Keyboard; HP PS/2 Business Slim Keyboard
<b>Mouse</b>	HP USB Optical Mouse; HP PS/2 Mouse; HP USB 1000dpi Laser Mouse; HP USB Hardened Mouse
<b>Network Card (integrated)</b>	Intel® I219LM Gigabit Ethernet
<b>Graphics (integrated)</b>	Intel® UHD Graphics
<b>Optical Storage</b>	HP 9.5mm Slim DVD-ROM; HP 9.5mm Slim DVD Writer
<b>Operating System</b>	Windows 10; FreeDOS 2.0
<b>Expansion Slot</b>	2 x full height PCI Express x1 (v3.0) slots; 2 x full height PCI Express x16 (v3.0) slots (one wired as a x4)
<b>USB Support</b>	4 x USB 2.0 ports - 2 front and 2 rear; 2 x USB 3.1 Gen 1 ports - rear; 4 x USB 3.1 Gen 2 ports - 2 front and 2 rear; 1 x USB Type-C™ 3.1 Gen 2 - front
<b>Rear I/O</b>	2 x DisplayPort™ 1.2; 1 x RJ-45 Network connector 1 x RS-232 Serial port (optional)
<b>Operating Voltage Range</b>	90 – 264 VAC
<b>Operating Line Frequency Range</b>	47 – 63 Hz

## BASIC JAPAN

Basic Japan Co., Ltd. Sugunami Tokyo, Japan  
 Phone: +81-3-5335-7651

E-mail: mail@basicjp.com / URL: www.basicjp.com

Design and specifications are subject to change without notice. E&OE.

Version I