

MS2470

Mariner Kit for use with HP EliteDesk 800 G3 SFF PC
(Horizontal mount)



The HP EliteDesk 800 G3 Small Form Factor (SFF) PC is marine type approved by all of the major international marine Classification Societies when it is installed in conjunction with our Mariner Kit MS2470.

The MS2470 Mariner Kit is designed to fit onto any horizontal surface and affords protection against the effects of vibration and shock experienced in the offshore marine environment and has been tested against IACS Unified Requirement E10 and the relevant sections of IEC60945 (see below right for test details).

This type approved combination of hardware and Mariner Kit can be used as the platform for your critical navigation, control, loading and general purpose applications (please check individual type approval certificates for any restrictions).

“Proven solutions for a demanding environment”



PRODUCT FEATURES

- ◆ Security, manageability, and performance in a modern compact design
- ◆ Powered for the enterprise, the HP EliteDesk 800 SFF is one of HP's most secure and manageable PCs featuring advanced performance, and configurability in a space saving, stylishly redesigned chassis for the modern workplace
- ◆ Intel® Q270 chipset supporting Intel® 7th Generation Core™ processors and Intel® 6th Generation Core™ processors, featuring integrated Intel® HD Graphics and Intel® vPro™ Technology (available with Core i5 and Core i7 processors)
- ◆ Rest easy with a PC that goes the distance and is designed to pass HP Total Test Process and MIL-STD 810G testing
- ◆ Four bays and four low profile slots, plus two additional M.2 connectors, and plenty of configurable ports
- ◆ Two front (including one fast charging) and two rear USB 2.0 port; two front and four rear USB 3.1 Gen I port; One front USB Type-C 3.1 Gen I port
- ◆ 2 x DisplayPort™ with multi-stream; 1 x RJ45 Network connector; 1 x RS-232 Serial port (optional)
- ◆ Support your environmental initiatives with energy-efficient PCs that are ENERGY STAR® certified and EPEAT® Gold registered where applicable/supported
- ◆ Compliant with the Restrictions of Hazardous Substances (RoHS) directive – 2011/65/EC
- ◆ Designed to comply with the Waste Electrical and Electronic Equipment (WEEE) directive – 2002/96/EC
- ◆ Three-year limited warranty on parts and labour as standard

This Mariner system is tested against the consolidated 'worst-case' requirements of the following major international marine Classification Societies:

ABS, BV, CCS, ClassNK, DNV GL, KR, LR, PRS, RINA

Tests included on the test programme are as follows:

- > Vibration, Shock, Static and Dynamic Inclination
- > Dry & Damp Heat, Low Temperature
- > Acoustic Noise, Compass Safe Distance
- > High Voltage, Power Supply Variation & Power Supply Failure
- > Conducted LF & RF, Electromagnetic Field
- > Radiated & Conducted Emissions, Electrostatic Discharge
- > Insulation Resistance, Burst / Fast Transients
- > Surge Immunity, Access to Dangerous Voltages

MS2470

Mariner Kit for use with HP EliteDesk 800 G3 Tower PC (Horizontal mount)

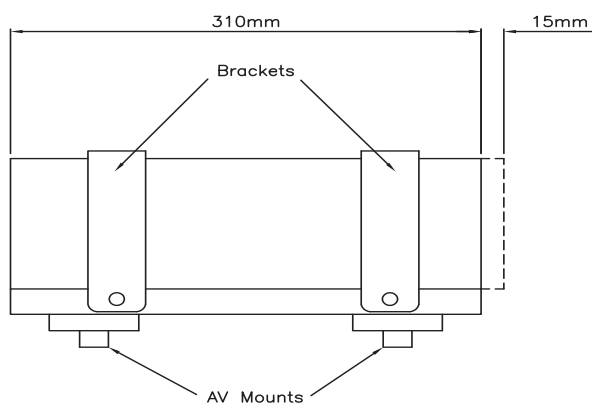
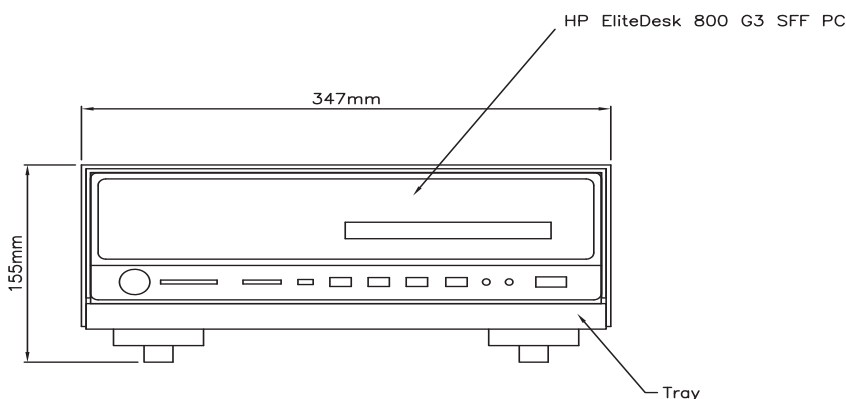

BASIC JAPAN

Basic Japan Co., Ltd. Suginami Tokyo, Japan
 Phone: +81-3-5335-7651
 E-mail: mail@basicjp.com
 URL: www.basicjp.com



Mariner Systems (UK) Limited

Oaklands Park • Wokingham • Berkshire • RG41 2FD • United Kingdom
 Telephone: +44 (0) 118 979 6020 • Facsimile: +44 (0) 118 979 6021
 sales@marinersystems.com • www.marinersystems.com

OPERATING GUIDELINES

Although all of our equipment is tested against extreme environmental conditions for the purposes of marine type approval, installation should take into account the following guidelines:

- > Keep the computer away from excessive moisture, direct moisture and the extremes of heat and cold and, wherever possible, ensure that the unit is operated within the manufacturer's specified operating ranges:

	Operating	Non-Operating
Temperature	+10° to +35°C (+50° to +95°F)	-30° to +60°C (-22° to +140°F)
Humidity	10% to 90% (non-condensing)	5% to 95% (non-condensing)

- > Leave at least 10.2 cm (4-inch) clearance on all vented sides of the computer to permit the required airflow
- > Never restrict airflow into the equipment by blocking any vents or air intakes
- > Occasionally clean the air vents on all vented sides of the computer
- > If the equipment is to be operated within a separate enclosure, intake and exhaust ventilation must be provided on the enclosure, and the same operating guidelines listed above will still apply

By following these guidelines you will maximise the life of your equipment and minimise service costs.

STATISTICS

Overall Fitted Dimensions	347mm (w) x 155mm (h) x 325mm (d)
Weight (Mariner Kit only)	Approx. 1.8 kg
Weight (including hardware)	Starting at 7.2 kg (depends upon configuration)
Chipset	Intel® Q270
Available Processors	Intel® 7th Generation Core™ i7, i5 & i3; Intel® 7th Generation Pentium®; Intel® 6th Generation Core™ i7, i5 & i3
Memory	Up to 64 GB DDR4-2400 SDRAM
Hard Drive(s)	500 GB to 1 TB 3.5-inch SATA (7,200 rpm); 500 GB to 1 TB 2.5-inch SATA (7,200 rpm); 500 GB to 1 TB 2.5-inch SATA (5,400 rpm) SSHD; 500 GB 2.5-inch SATA SED Opal 2 (7,200 rpm); 256 GB 2.5-inch SATA TLC SED Opal 2 SSD; 256 GB 2.5-inch SATA SSD; 256 GB Turbo G2 PCIe TLC SSD
Keyboard	HP USB Business Slim Keyboard; HP PS/2 Business Slim Keyboard
Mouse	HP USB Mouse; HP PS/2 Mouse; HP USB 1000dpi Laser Mouse; HP USB Hardened Mouse
Network Card (integrated)	Intel® I219LM Gigabit Ethernet
Graphics (integrated)	Intel® HD Graphics
Optical Storage	HP 9.5mm Slim DVD-ROM; HP 9.5mm Slim DVD-RW
Audio (integrated)	Realtek ALC221 with combo microphone/headphone jack, line-in and line-out rear ports (3.5mm), internal speaker
Operating System	Windows 10; Windows 7 (available through downgrade rights from Windows 10 Pro)
Expansion Slot	2 x low profile PCI Express x16 (v3.0) slots (one wired as a x4); 2 x low profile PCI Express x1 (v3.0) slots
USB Support	4 x USB 2.0 ports – 2 front and 2 rear 6 x USB 3.1 ports – 2 front and 4 rear 1 x USB Type-C™ 3.1 Gen1
Rear I/O	2 x DisplayPort™ with multi-stream 1 x RJ-45 Network connector 1 x RS-232 Serial port (optional)
Operating Voltage Range	90 – 264 VAC
Operating Line Frequency Range	47 – 63 Hz