

# MSI430

**Mariner Kit for use with the HP EliteDisplay E241i 24-inch widescreen LED backlit IPS monitor (Desk mount)**

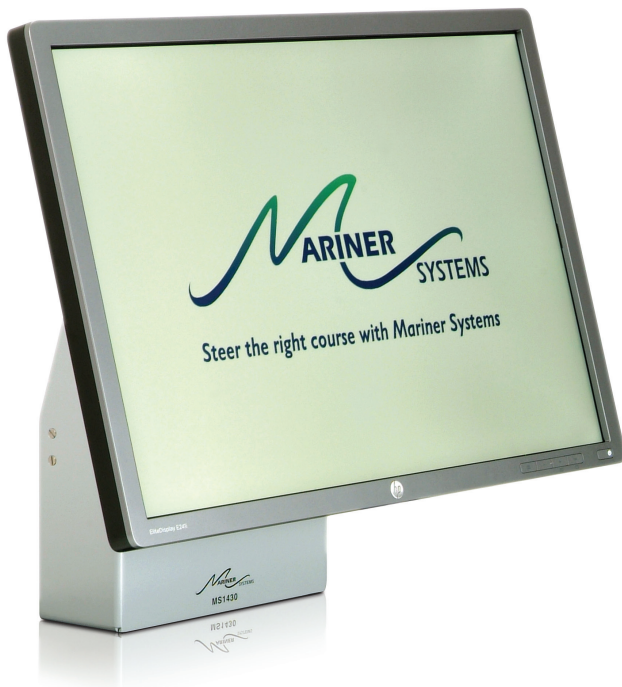

The HP EliteDisplay E241i 24-inch widescreen LED backlit IPS monitor is type-approved by all of the major international marine Classification Societies when it is installed in conjunction with our Mariner Kit MSI430.

The MSI430 Mariner Kit is designed to fit onto any horizontal surface and affords protection against the effects of vibration and shock experienced in the offshore marine environment. The combination has been type-tested against IACS Unified Requirement E10 and the relevant sections of IEC60945 (see below right for test details).

This type-approved combination of hardware and Mariner Kit can be used as the platform for your critical navigation, control, loading and general-purpose applications (please check individual type-approval certificates for any restrictions).

Please note that although the monitor does retain its standard functionality we do not offer an automatic dimming function and it can not therefore be used in the front of the bridge where it may affect night vision. However, the LED backlit IPS monitor can be used in any area where night vision is not an issue.

**“Steer the right course  
with Mariner Systems”**



## **KEY FEATURES OF THE HP ELITEDISPLAY E241I 24-INCH LED BACKLIT IPS MONITOR:**

- ◆ Experience great 178-degree viewing angles and stunning colour integrity from In-Plane Switching (IPS) technology.
- ◆ Crisp, clear content on this 24-inch diagonal, 16:10 aspect ratio screen from the high 5,000,000:1 dynamic contrast ratio
- ◆ Native 1920 x 1200 resolution with over 16 million colours
- ◆ Connect with VGA, DVI and DisplayPort inputs and integrated two-port USB hub
- ◆ The on-screen display button controls on the monitor front allow quick and easy adjustment of brightness, contrast and numerous other settings
- ◆ Personalise your screen with HP Display Assistant software and view open applications on your connected displays
- ◆ Lower your costs with an intelligent, energy-efficient design that is ENERGY STAR® and TCO qualified and EPEAT® Gold registered
- ◆ The display also includes mercury-free display backlights, a low-halogen design and arsenic-free display glass
- ◆ 98.6% recyclable when properly disposed of at end of life
- ◆ Compliant with the Restrictions of Hazardous Substances (RoHS) directive – 2002/95/EC
- ◆ Designed to comply with the Waste Electrical and Electronic Equipment (WEEE) directive – 2002/96/EC
- ◆ Three-year standard limited warranty

This Mariner system is type-tested against the consolidated, 'worst-case' requirements of all the major international marine Classification Societies:

### **ABS, BV, CCS, DNV, GL, KR, LR, NKK, PRS, RINA**

Type-tests included on the test programme are as follows:

- > Vibration, Shock, Static and Dynamic Inclination
- > Dry & Damp Heat, Low Temperature
- > Acoustic Noise, Compass Safe Distance
- > High Voltage, Power Supply Variation & Power Supply Failure
- > Conducted LF & RF, Electromagnetic Field
- > Radiated & Conducted Emissions, Electrostatic Discharge
- > Insulation Resistance, Burst/Fast Transients
- > Surge Immunity, Access to Dangerous Voltages

# MSI430

## Mariner Kit for use with the HP EliteDisplay E241i 24-inch widescreen LED backlit IPS monitor (Desk mount)

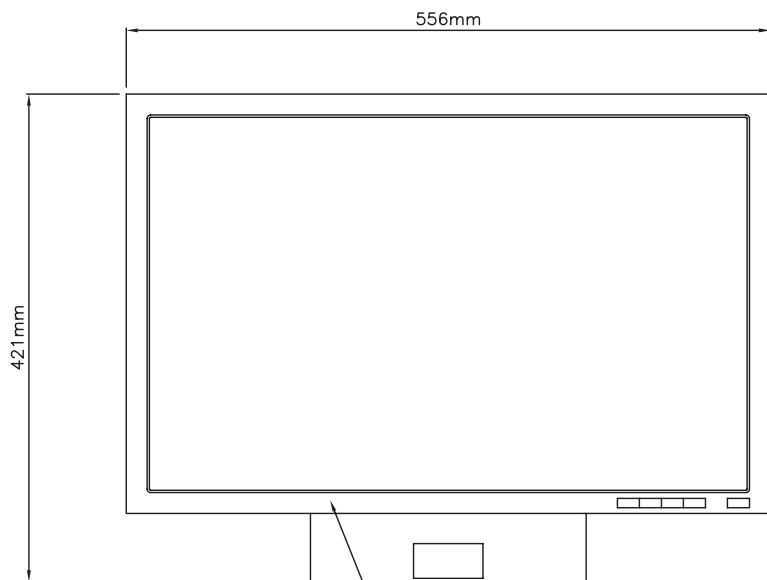

HP EliteDisplay E241i 24" Monitor

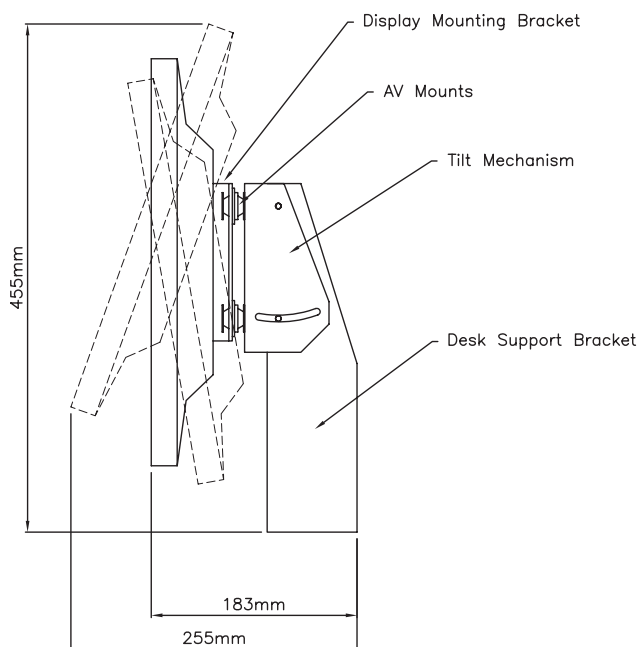

### Mariner Systems (UK) Limited

Oaklands Park • Wokingham • Berkshire • RG41 2FD • United Kingdom  
 Telephone: +44 (0) 118 979 6020 • Facsimile: +44 (0) 118 979 6021  
 sales@marinersystems.com • www.marinersystems.com

## OPERATING GUIDELINES:

Although all our equipment is tested against extreme environmental conditions for the purposes of marine type-approval, installation should take into account the following guidelines:

- > Keep the monitor away from excessive moisture, direct moisture and the extremes of heat and cold to ensure, where possible, that the unit is within the following operating/non-operating ranges:

	Operating	Non-operating
<b>Temperature</b>	+5° to +35°C (+41° to +95°F)	-20° to +60°C (-4° to +140°F)
<b>Humidity</b>	25% to 85% (non-condensing)	5% to 95% (38.7°C max wet-bulb)

- > Leave clearance on all vented sides of the monitor to permit the required airflow
- > Never restrict airflow into the monitor by blocking any vents or air intakes
- > If the monitor is to be operated within a separate enclosure, suitable ventilation should be provided

By following these guidelines you will maximise the life of your equipment and minimise service costs.

## STATISTICS

<b>Overall Fitted Dimensions (max)</b>	556 x 455 x 255 mm (w x h x d)
<b>Weight (Mariner Kit only)</b>	1.5 kg
<b>Weight (including hardware)</b>	5.6 kg
<b>Panel Type</b>	IPS (In-Plane Switching) with LED backlight
<b>Viewable Image Area (diagonal)</b>	24 in (61 cm)
<b>Panel Active Area (w x h)</b>	20.4 x 12.7 in (51.84 x 32.4 cm)
<b>Aspect Ratio</b>	16:10
<b>Native Resolution</b>	1920 x 1200 at 60 Hz
<b>Viewing Angle (typical)</b>	Up to 178 degrees horizontal and 178 degrees vertical (10:1 contrast ratio)
<b>Brightness (typical)</b>	250 nits (cd/m <sup>2</sup> )
<b>Contrast Ratio (typical)</b>	1000:1
<b>Dynamic Contrast Ratio (typical)</b>	5,000,000:1
<b>Response Time (typical)</b>	8 ms (grey to grey)
<b>Pixel Pitch</b>	0.270 mm
<b>Backlight Lamp Life (to half brightness)</b>	30,000 hours minimum
<b>Buttons or Switches</b>	Power on/off; 4-button OSD
<b>Plug and Play</b>	Yes
<b>Input Connectors</b>	VGA, DVI-D and DisplayPort 1.2 connectors; HDCP support
<b>USB 2.0 Hub</b>	Three ports (one upstream, two downstream)
<b>Power Source</b>	Auto-Sensing, 90 to 265 VAC at 45 to 63 Hz
<b>Typical Power Consumption</b>	35 W
<b>Maximum Power Consumption</b>	40 W
<b>Mariner Kit Tilt Range</b>	10 degrees down; 20 degrees up

## BASIC JAPAN

Basic Japan株式会社 Suginami Tokyo, Japan  
 Phone: 03-5335-7651  
 E-mail: mail@basicjp.com  
 URL: www.basicjp.com

# MSI435

**Mariner Kit for use with the HP EliteDisplay E241i 24-inch widescreen LED backlit IPS monitor (Wall mount)**



The HP EliteDisplay E241i 24-inch widescreen LED backlit IPS monitor is type-approved by all of the major international marine Classification Societies when it is installed in conjunction with our Mariner Kit MSI435.

The MSI435 Mariner Kit is designed to fit onto any vertical surface and affords protection against the effects of vibration and shock experienced in the offshore marine environment. The combination has been type-tested against IACS Unified Requirement E10 and the relevant sections of IEC60945 (see below right for test details).

This type-approved combination of hardware and Mariner Kit can be used as the platform for your critical navigation, control, loading and general-purpose applications (please check individual type-approval certificates for any restrictions).

Please note that although the monitor does retain its standard functionality we do not offer an automatic dimming function and it can not therefore be used in the front of the bridge where it may affect night vision. However, the LED backlit IPS monitor can be used in any area where night vision is not an issue.

**“Proven solutions for a demanding environment”**



## KEY FEATURES OF THE HP ELITEDISPLAY E241I 24-INCH LED BACKLIT IPS MONITOR:

- ◆ Experience great 178-degree viewing angles and stunning colour integrity from In-Plane Switching (IPS) technology.
- ◆ Crisp, clear content on this 24-inch diagonal, 16:10 aspect ratio screen from the high 5,000,000:1 dynamic contrast ratio
- ◆ Native 1920 x 1200 resolution with over 16 million colours
- ◆ Connect with VGA, DVI and DisplayPort inputs and integrated two-port USB hub
- ◆ The on-screen display button controls on the monitor front allow quick and easy adjustment of brightness, contrast and numerous other settings
- ◆ Personalise your screen with HP Display Assistant software and view open applications on your connected displays
- ◆ Lower your costs with an intelligent, energy-efficient design that is ENERGY STAR® and TCO qualified and EPEAT® Gold registered
- ◆ The display also includes mercury-free display backlights, a low-halogen design and arsenic-free display glass
- ◆ 98.6% recyclable when properly disposed of at end of life
- ◆ Compliant with the Restrictions of Hazardous Substances (RoHS) directive – 2002/95/EC
- ◆ Designed to comply with the Waste Electrical and Electronic Equipment (WEEE) directive – 2002/96/EC
- ◆ Three-year standard limited warranty

This Mariner system is type-tested against the consolidated, 'worst-case' requirements of all the major international marine Classification Societies:

### ABS, BV, CCS, DNV, GL, KR, LR, NKK, PRS, RINA

Type-tests included on the test programme are as follows:

- > Vibration, Shock, Static and Dynamic Inclination
- > Dry & Damp Heat, Low Temperature
- > Acoustic Noise, Compass Safe Distance
- > High Voltage, Power Supply Variation & Power Supply Failure
- > Conducted LF & RF, Electromagnetic Field
- > Radiated & Conducted Emissions, Electrostatic Discharge
- > Insulation Resistance, Burst/Fast Transients
- > Surge Immunity, Access to Dangerous Voltages

# MSI435

**Mariner Kit for use with the HP EliteDisplay E241i 24-inch widescreen LED backlit IPS monitor (Wall mount)**

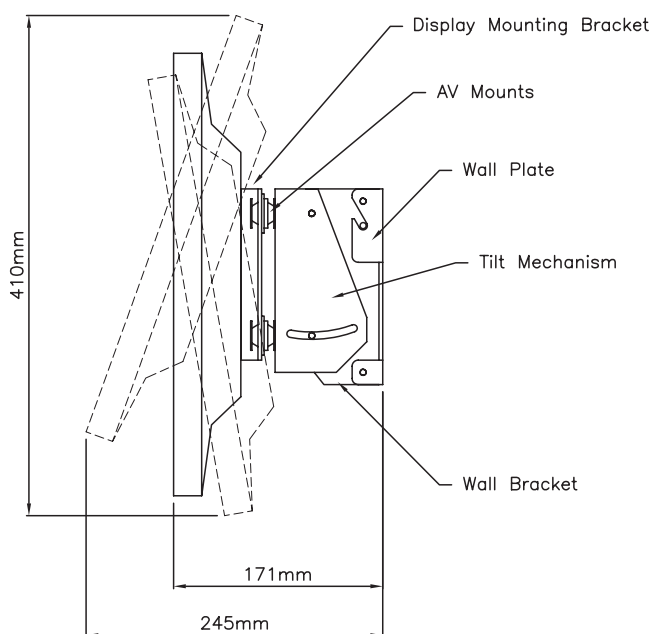
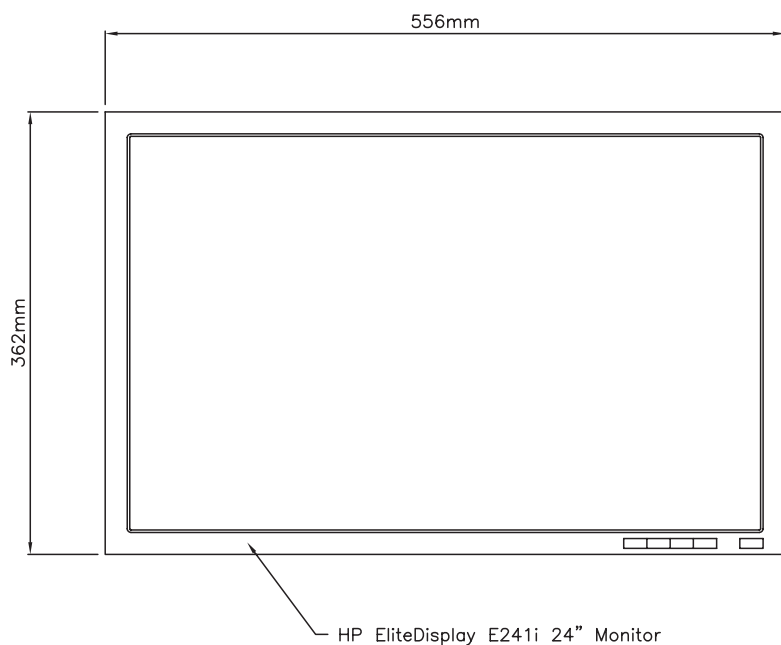

**Mariner Systems (UK) Limited**

Oaklands Park • Wokingham • Berkshire • RG41 2FD • United Kingdom  
 Telephone: +44 (0) 118 979 6020 • Facsimile: +44 (0) 118 979 6021  
 sales@marinersystems.com • www.marinersystems.com

## OPERATING GUIDELINES:

Although all our equipment is tested against extreme environmental conditions for the purposes of marine type-approval, installation should take into account the following guidelines:

- > Keep the monitor away from excessive moisture, direct moisture and the extremes of heat and cold to ensure, where possible, that the unit is within the following operating/non-operating ranges:

	Operating	Non-operating
<b>Temperature</b>	+5° to +35°C (+41° to +95°F)	-20° to +60°C (-4° to +140°F)
<b>Humidity</b>	25% to 85% (non-condensing)	5% to 95% (38.7°C max wet-bulb)

- > Leave clearance on all vented sides of the monitor to permit the required airflow
- > Never restrict airflow into the monitor by blocking any vents or air intakes
- > If the monitor is to be operated within a separate enclosure, suitable ventilation should be provided

By following these guidelines you will maximise the life of your equipment and minimise service costs.

## STATISTICS

<b>Overall Fitted Dimensions (max)</b>	<b>556 x 410 x 245 mm (w x h x d)</b>
<b>Weight (Mariner Kit only)</b>	<b>1.2 kg</b>
<b>Weight (including hardware)</b>	<b>5.3 kg</b>
<b>Panel Type</b>	<b>IPS (In-Plane Switching) with LED backlight</b>
<b>Viewable Image Area (diagonal)</b>	<b>24 in (61 cm)</b>
<b>Panel Active Area (w x h)</b>	<b>20.4 x 12.7 in (51.84 x 32.4 cm)</b>
<b>Aspect Ratio</b>	<b>16:10</b>
<b>Native Resolution</b>	<b>1920 x 1200 at 60 Hz</b>
<b>Viewing Angle (typical)</b>	<b>Up to 178 degrees horizontal and 178 degrees vertical (10:1 contrast ratio)</b>
<b>Brightness (typical)</b>	<b>250 nits (cd/m<sup>2</sup>)</b>
<b>Contrast Ratio (typical)</b>	<b>1000:1</b>
<b>Dynamic Contrast Ratio (typical)</b>	<b>5,000,000:1</b>
<b>Response Time (typical)</b>	<b>8 ms (grey to grey)</b>
<b>Pixel Pitch</b>	<b>0.270 mm</b>
<b>Backlight Lamp Life (to half brightness)</b>	<b>30,000 hours minimum</b>
<b>Buttons or Switches</b>	<b>Power on/off; 4-button OSD</b>
<b>Plug and Play</b>	<b>Yes</b>
<b>Input Connectors</b>	<b>VGA, DVI-D and DisplayPort 1.2 connectors; HDCP support</b>
<b>USB 2.0 Hub</b>	<b>Three ports (one upstream, two downstream)</b>
<b>Power Source</b>	<b>Auto-Sensing, 90 to 265 VAC at 45 to 63 Hz</b>
<b>Typical Power Consumption</b>	<b>35 W</b>
<b>Maximum Power Consumption</b>	<b>40 W</b>
<b>Mariner Kit Tilt Range</b>	<b>10 degrees down; 20 degrees up</b>

## BASIC JAPAN

Basic Japan株式会社 Sugunami Tokyo, Japan  
 Phone: 03-5335-7651  
 E-mail: mail@basicjp.com  
 URL: www.basicjp.com

# MSI440

**Mariner Kit for use with the HP EliteDisplay E241i 24-inch widescreen LED backlit IPS monitor (Console mount)**



The HP EliteDisplay E241i 24-inch widescreen LED backlit IPS monitor is type-approved by all of the major international marine Classification Societies when it is installed in conjunction with our Mariner Kit MSI440.

The MSI440 Mariner Kit is designed to fit into a console cut-out and affords protection against the effects of vibration and shock experienced in the offshore marine environment. The combination has been type-tested against IACS Unified Requirement E10 and the relevant sections of IEC60945 (see below right for test details).

This type-approved combination of hardware and Mariner Kit can be used as the platform for your critical navigation, control, loading and general-purpose applications (please check individual type-approval certificates for any restrictions).

Please note that although the monitor does retain its standard functionality we do not offer an automatic dimming function and it can not therefore be used in the front of the bridge where it may affect night vision. However, the LED backlit IPS monitor can be used in any area where night vision is not an issue.

**“World-leading type-approved computer hardware”**



## KEY FEATURES OF THE HP ELITEDISPLAY E241I 24-INCH LED BACKLIT IPS MONITOR:

- ◆ Experience great 178-degree viewing angles and stunning colour integrity from In-Plane Switching (IPS) technology.
- ◆ Crisp, clear content on this 24-inch diagonal, 16:10 aspect ratio screen from the high 5,000,000:1 dynamic contrast ratio
- ◆ Native 1920 x 1200 resolution with over 16 million colours
- ◆ Connect with VGA, DVI and DisplayPort inputs and integrated two-port USB hub
- ◆ The on-screen display button controls on the monitor front allow quick and easy adjustment of brightness, contrast and numerous other settings
- ◆ Personalise your screen with HP Display Assistant software and view open applications on your connected displays
- ◆ Lower your costs with an intelligent, energy-efficient design that is ENERGY STAR® and TCO qualified and EPEAT® Gold registered
- ◆ The display also includes mercury-free display backlights, a low-halogen design and arsenic-free display glass
- ◆ 98.6% recyclable when properly disposed of at end of life
- ◆ Compliant with the Restrictions of Hazardous Substances (RoHS) directive – 2002/95/EC
- ◆ Designed to comply with the Waste Electrical and Electronic Equipment (WEEE) directive – 2002/96/EC
- ◆ Three-year standard limited warranty

This Mariner system is type-tested against the consolidated, 'worst-case' requirements of all the major international marine Classification Societies:

### ABS, BV, CCS, DNV, GL, KR, LR, NKK, PRS, RINA

Type-tests included on the test programme are as follows:

- > Vibration, Shock, Static and Dynamic Inclination
- > Dry & Damp Heat, Low Temperature
- > Acoustic Noise, Compass Safe Distance
- > High Voltage, Power Supply Variation & Power Supply Failure
- > Conducted LF & RF, Electromagnetic Field
- > Radiated & Conducted Emissions, Electrostatic Discharge
- > Insulation Resistance, Burst/Fast Transients
- > Surge Immunity, Access to Dangerous Voltages

# MS I440

**Mariner Kit for use with the HP EliteDisplay E24li 24-inch widescreen LED backlit IPS monitor (Console mount)**

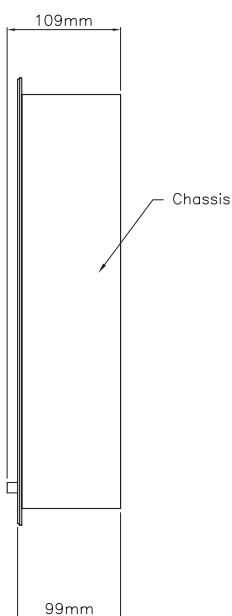
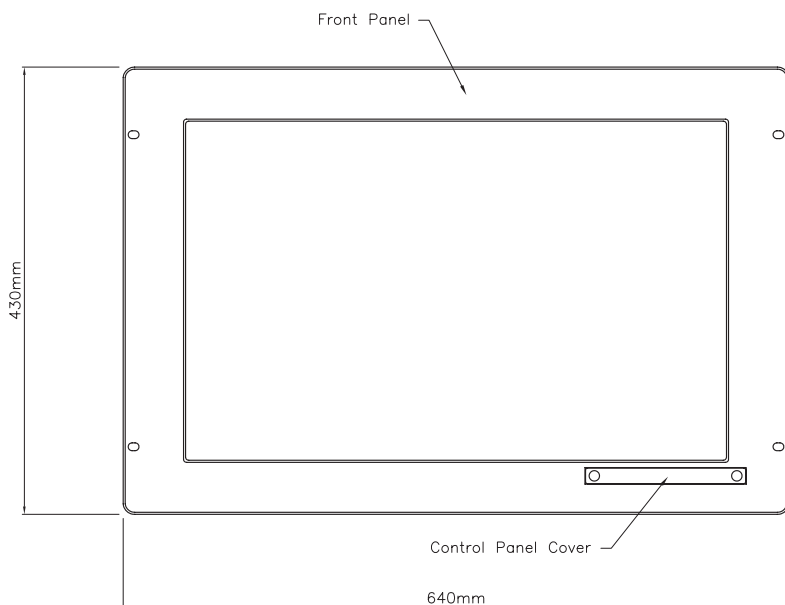

## OPERATING GUIDELINES:

Although all our equipment is tested against extreme environmental conditions for the purposes of marine type-approval, installation should take into account the following guidelines:

- > Keep the monitor away from excessive moisture, direct moisture and the extremes of heat and cold to ensure, where possible, that the unit is within the following operating/non-operating ranges:

	Operating	Non-operating
<b>Temperature</b>	+5° to +35°C (+41° to +95°F)	-20° to +60°C (-4° to +140°F)
<b>Humidity</b>	25% to 85% (non-condensing)	5% to 95% (38.7°C max wet-bulb)

- > Leave clearance on all vented sides of the monitor to permit the required airflow
- > Never restrict airflow into the monitor by blocking any vents or air intakes
- > If the monitor is to be operated within a separate enclosure, suitable ventilation should be provided

By following these guidelines you will maximise the life of your equipment and minimise service costs.

## STATISTICS

<b>Overall Fitted Dimensions (max)</b>	<b>640 x 430 x 109 mm (w x h x d)</b>
<b>Weight (Mariner Kit only)</b>	<b>7.8 kg</b>
<b>Weight (including hardware)</b>	<b>11.9 kg</b>
<b>Panel Type</b>	<b>IPS (In-Plane Switching) with LED backlight</b>
<b>Viewable Image Area (diagonal)</b>	<b>24 in (61 cm)</b>
<b>Panel Active Area (w x h)</b>	<b>20.4 x 12.7 in (51.84 x 32.4 cm)</b>
<b>Aspect Ratio</b>	<b>16:10</b>
<b>Native Resolution</b>	<b>1920 x 1200 at 60 Hz</b>
<b>Viewing Angle (typical)</b>	<b>Up to 178 degrees horizontal and 178 degrees vertical (10:1 contrast ratio)</b>
<b>Brightness (typical)</b>	<b>250 nits (cd/m<sup>2</sup>)</b>
<b>Contrast Ratio (typical)</b>	<b>1000:1</b>
<b>Dynamic Contrast Ratio (typical)</b>	<b>5,000,000:1</b>
<b>Response Time (typical)</b>	<b>8 ms (grey to grey)</b>
<b>Pixel Pitch</b>	<b>0.270 mm</b>
<b>Backlight Lamp Life (to half brightness)</b>	<b>30,000 hours minimum</b>
<b>Buttons or Switches</b>	<b>Power on/off; 4-button OSD</b>
<b>Plug and Play</b>	<b>Yes</b>
<b>Input Connectors</b>	<b>VGA, DVI-D and DisplayPort 1.2 connectors; HDCP support</b>
<b>USB 2.0 Hub</b>	<b>Three ports (one upstream, two downstream)</b>
<b>Power Source</b>	<b>Auto-Sensing, 90 to 265 VAC at 45 to 63 Hz</b>
<b>Typical Power Consumption</b>	<b>35 W</b>
<b>Maximum Power Consumption</b>	<b>40 W</b>
<b>Mariner Kit Tilt Range</b>	<b>Not applicable</b>



### Mariner Systems (UK) Limited

Oaklands Park • Wokingham • Berkshire • RG41 2FD • United Kingdom  
Telephone: +44 (0) 118 979 6020 • Facsimile: +44 (0) 118 979 6021  
sales@marinersystems.com • www.marinersystems.com

## BASIC JAPAN

Basic Japan株式会社 Suginami Tokyo, Japan  
Phone: 03-5335-7651  
E-mail: mail@basicjp.com  
URL: www.basicjp.com