

WMG-821GEPAD



Introduction

Overview

WMG-821GEPAD は、EN 50155, EN 50121-4, UL 60950-1 の要求にミートしており、鉄道・線路沿や、鉄道車両、車両等の輸送業界でのセキュアな通信用途向けにデザインされています。WMG-821GEPAD は、Industrial 8ポートの10/100Base-T(X) M12 UTP 及び 2ポートの10/100/1000Base-T(X) M12 UTP を有しており、さらに広域温度モデル (-40 to 80°C)をもサポートしております。IP67レートにより、ダスト・湿気・油や水の浸入に対する耐性を持っています。搭載されるM12コネクタにより水密を保持し、振動や衝撃等の悪環境下でも確実なコネクションを実現します。安全性のために、冗長化され・ワイドレンジな供給電源仕様であり (12/24/48VDC) + (110/220VDC (88-300VDC) or 110/220VAC (88-264VAC)), 逆極性・過負荷防止仕様となっています。

WMG-821GEPADは、最新のEthernet機能である STP/RSTP/MSTP/ ITU-T G.8032 ERPS・multiple Direct-Ring for redundant cabling・IGMP・VLAN・QoS・Security・IPv6・bandwidth control・port mirroring・cable diagnostic・IEEE802.3az EEE (Energy Efficient Ethernet) (マネジメント ツウ オフ ティアスブル ワーク アクション)をサポートしております。Ethernet Direct社のEN 50155 switchは、オートバイパス機能搭載によりデジチェーン・リアトポロジーネットワーク下での突然の電力損失に備えます。もし、列車内のswitchにパワーダウンが発生した場合にバイパスリレーにより自動的に内部回路からバックアップされ、隣の機器とのリンクを保持します。

この機能により、各端末からバックボーン・さらに上の層のネットワークへの100%安全な通信が保証されます。さらにEN 50155 認証により入力電圧・サージ・EFT・ESD・振動衝撃についても保護されています。

Features

High Performance Network Switching Technology

- Complies with IEEE standards
- Provides 8 x 10/100/1000Base-T(X) with M12 connector (8-pin, female, A-Coded) and supporting of Green Ethernet IEEE802.3az EEE (Energy Efficient Ethernet) function
- Provides 2 x 10/100/1000Base-T(X) with M12 connector (8-pin, female, A-Coded) and supporting bypass function
- Supports various network redundant solutions, including Direct-Ring, Direct-Chain, Join-Ring, STP, RSTP, MSTP and ITU-T G.8032
- Proprietary ultra high speed redundant technology with < 10ms recovery time @ 250 devices
- Supports IEEE1588 PTP V2 for precise time synchronization, to operate in Ordinary-Boundary, Peer to Peer Transparent Clock, End to End Transparent Clock, Master, Slave mode by each port
- Supports various network security solutions, Port and MAC based IEEE802.1X, RADIUS, ACL, TACACS+, HTTP/HTTPS, SSL/SSH v2
- Supports DHCP Server/Client/Relay/Snooping option 82/Relay option 82
- Network traffic priority, QoS, Traffic classification QoS, CoS, bandwidth control for Ingress/Egress, broadcast storm control, DiffServ
- Supports IEEE802.1Q VLAN, MAC-based VLAN, IP Subnet-based VLAN, Protocol-based VLAN, VLAN translation, GVRP/MVRP

- Supports IGMP/MLD snooping V1/V2/V3, IGMP Filtering/Throttling, IGMP query, IGMP proxy reporting, MLD snooping
- Supports dynamic IEEE 802.3ad LACP Link Aggregation, Static Link Aggregation
- Supports RMON, MIB II, Port mirroring, Syslog, IEEE802.1ab LLDP for network monitoring
- Supports IPv6 Telnet server, ICMIPv6
- Supports CLI, Web based management, SNMP v1/v2c/v3, Telnet server for management
- Supports firmware upgrade via TFTP & HTTP with redundant firmware option

Reliable Power Design

- Supports 12/24/48VDC + (110/220VDC (88-300VDC) or 110/220VAC (88-264VAC)) redundant power input with IP67 M23 connector
- Power reverse polarity protection and overload current protection

Robust Industrial Design

- EN 50155 certified for Railway Applications and IEC 61373 test passed for vibration and shock resistant
- EN 50121-4 certified for Railway Applications (Track Side)
- EN 61000-6-2 and EN 61000-6-4 certified to use in heavy industrial environment
- Robust industrial design case complies with IP67 housing standard
- Supports operating temperature -40 to 80°C
- Wall mount or optional DIN-Rail mounting installation

Specifications

Hardware Specifications

Interface

Total Ports: 10 ports

M12 Ports: 8 x 10/100/1000Base-T(X) M12 connector (8-pin, female, A-Coded) and 2 x 10/100/1000Base-T(X) M12 connector (8-pin, female, A-Coded), auto-negotiation speed, Full/Half duplex, auto MDI/MDI-X

Console Port: RS-232, M12 connector (5-pin, male, A-Coded)

LEDs: System: Power 1 (Green), Power 2 (Green), Fault (Amber), CPU Act (Green), Ring Master (Amber)

M12 Ports: 10/100 Link/Active (Green), 1000 Link/Active (Amber)

Alarm Contact: 1A@24VDC, M12 connector (5-pin, male, A-Coded)

CPU Watchdog: Supported

Power Requirements

Power Input: 12 to 48VDC + (110/220VDC (88-300VDC) or 110/220VAC (88-264VAC)), M23 connector (5-pin, male), redundant dual inputs

Power Consumption: 12VDC/11.9W, 24VDC/12.3W, 48VDC/14W, 110VAC_VDC/11.9W, 220VAC_VDC/11.9W

Power Protection: Reverse polarity protection, overload current protection

Physical

Dimensions: IP67 standard, 240mm (W) x 168mm (H) x 70mm (D)

Installation: Wall mount or optional DIN-Rail mounting

Environmental

Operating Temperature: -40 to 80°C

Storage Temperature: -40 to 85°C

Operating Humidity: 5% to 95% RH (Non-condensing)

Technical Standard:

IEEE 802.3 10Base-T Ethernet
 IEEE 802.3u 100Base-TX/100Base-FX
 IEEE 802.3ab 1000Base-T
 IEEE 802.3x Flow Control
 IEEE 802.3ad Port trunk with LACP
 IEEE 802.3ac VLAN Tagging extension (Max. frame size extended to 1522 Bytes)
 IEEE 802.3az EEE (Energy Efficient Ethernet)
 IEEE 802.1D Spanning Tree
 IEEE 802.1w Rapid Spanning Tree
 IEEE 802.s Multiple Spanning Tree
 IEEE 802.1p Class of Service
 IEEE 802.1Q VLAN Tagging
 IEEE 802.1X User Authentication (Radius)
 IEEE 802.1AB LLDP
 ITU-T G.8032 / Y.1344 ERPS (Ethernet Ring Protection Switching)
Protocol Technology: CSMA/CD
Switching Architecture: Store and Forward

Regulatory Approvals

EMC: CE, EN 61000-6-2, EN 61000-6-4
EMI: FCC Part 15 Subpart B Class A, CE EN55022 Class A
EMS: EN 61000-4-2, EN 61000-4-3, EN 61000-4-4, EN 61000-4-5, EN 61000-4-6, EN 61000-4-8,
Safety: UL 60950-1
Railway Application: EN 50155 (Certified)

Railway Application (Track Side): EN 50121-4 (Certified)

Shock: IEC 61373
Vibration: IEC 61373
Free Fall: IEC 60068-2-32
Environmental: WEEE, RoHS
MTBF: 349,564 hours based on Mil-Hdbk-217F, GB
Warranty: 5 years

Software Specifications

Redundancy:

Direct-Ring, Direct-Chain, Join-Ring < 10ms recovery time,
 (Each switch can configure up to 5 rings regardless of Direct-Ring, Direct-Chain, Join-Ring,
 and each ring can contents 250 units of switches), supports loop protection
 STP/RSTP/MSTP
 ITU-T G.8032 / Y.1344 ERPS with < 50ms recovery time
 (Single Ring, Sub-Ring, Multiple ring topology networks)
 Link Aggregation: Static supports up to 5 trunk groups
 Dynamic (IEEE 802.3ad LACP) supports up to 5 trunk groups

VLAN:

VID 1 to 4094
 VLAN group up to 4094 groups
 IEEE 802.1ad Q-in-Q
 MAC-based VLAN (256 entries)
 IP Subnet-based VLAN (128 entries)
 Protocol-based VLAN (Ethernet, SNAP, LLC), (128 entries)
 VLAN Translation (256 entries)
 GVRP (GARP VLAN Registration Protocol)
 MVR (Multicast VLAN Registration)

QoS:

Port based and IEEE 802.1p based CoS
 QoS determined by port, per port 8 active priorities queues
 IP Precedence based Co, IP DSCP based CoS
 DiffServ (RFC 2474) Remarking

Bandwidth Control:

Ingress/Egress

Storm Control:

Unicast, Broadcast, Multicast

IGMP/MLD Snooping:

IGMP Snooping v1/v2/v3, MLD Snooping v1/v2
 Port Filtering Profile
 Throttling, Fast Leave
 Maximum Multicast Group: Up to 1022 entries
 Query / Static Router Port

Security:

IEEE 802.1X (Port-based, MAC-based), RADIUS, TACACS+ 3.0
 Supports ACL, no. of rules up to 256 entries
 HTTP/HTTPS, SSL, SSH v2
 Local Authentication
 Remote Access Security: RADIUS, TACACS+
 Management interface access filtering via Web, Telnet/SSH, CLI console

Management:

SNMP, Web, Telnet/SSH, CLI management
 TFTP/HTTP backup/restore configurations
 Firmware upgrade via TFTP/HTTP, supports dual firmware
 RMON I (1, 2, 3, 9 group), RMON II
 RFC1213 MIB II, Private MIB
 Supports UPnP, IP Source Guard, Port Mirroring
 Warning message sends to syslog, e-mail, alarm relay
 DNS Client, Proxy
 LLDP: LLDP-MED

System Log:

Supports local system log and remote Syslog server

DHCP:

Server, Client, Relay, Snooping
 Snooping option 82, Relay option 82

Time Management:

IEEE1588 PTP V2: Ordinary-Boundary, Peer to Peer Transparent Clock, End to End
 Transparent Clock, Master, Slave
 NTP/SNTP Client

IPv6:

IPv6 Management Telnet Server/ICMP v6
 SNMP over IPv6, HTTP over IPv6, SSH over IPv6, IPv6 Telnet, IPv6 NTP (Client), IPv6 SNTP
 (Client), IPv6 TFTP, IPv6 QoS, IPv6 ACL (256 entries)

Green Ethernet:

Supports IEEE802.3az EEE (Energy Efficient Ethernet): Management to optimize the power
 consumption
 Determine the cable length and lowering the power for ports work with short cable
 Lower the power for a port when there is no link
 LED Power Management: Adjustment on LEDs intensity

Cable Diagnostic: (Copper ports only)

Shows physical status of the UTP cable, in order to get more accurate result the cable length
 suggestion is 7-140 meters

Dimensions (unit=mm)

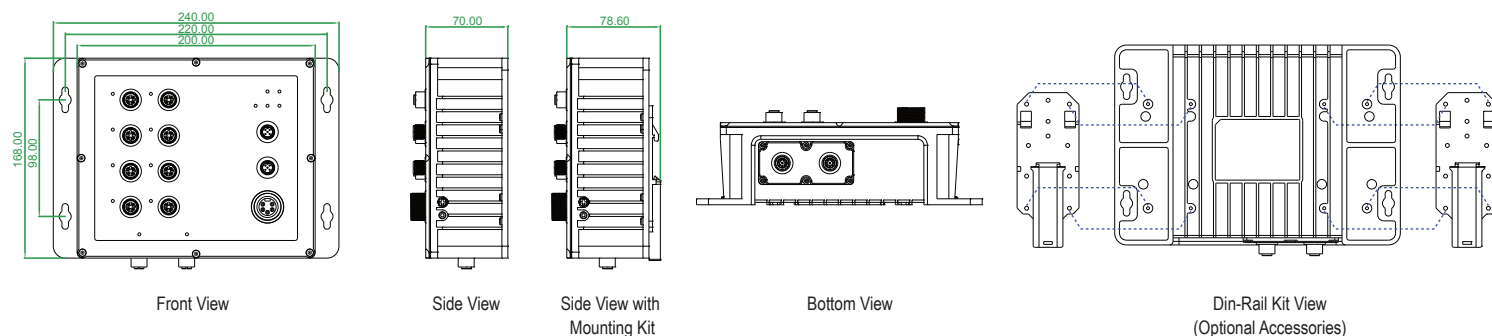

Ordering Information

WMG-821GEPAD

Industrial 8 x 10/100/1000Base-T(X) + 2 x 10/100/1000Base-T(X) EN 50155 IP67 M12 Full Gigabit Managed Ethernet Switch, -40 to 80°C, (IEEE 1588 PTP)

Optional Accessories

Cables

		
<p>WA-M12AM8-RJ-1M M12 A-Code Male (8-Pin) to RJ-45 Gigabit Ethernet Cable AWG 24, IP67, 1M</p>	<p>WA-M12AF5-O-1M M12 A-Coded Female (5-Pin) to Open Wire Alarm Contact Cable AWG 22, IP67, 1M</p>	<p>WA-M23F5-O-1M M23 Female (5-Pin) to Open Wire Power Cable AWG 16, IP67, 1M</p>

****Note: All cable length customisable.**

Connectors & Others

		
<p>WA-M12AM8C M12 A-Coded Male (8-Pin) Connector</p>	<p>WA-M12AF5C M12 A-Coded Female (5-Pin) Connector</p>	<p>WA-001D Din-Rail Mounting Kit</p>

BASIC JAPAN

Basic Japan株式会社 Sugunami Tokyo, Japan

Phone: 03-5335-7651

E-mail: mail@basicjp.com

URL: www.basicjp.com